



TN-9000C
INSTRUCTION MANUAL
PREMIUM ELECTRONIC DIRECT-DRIVE HIGH-SPEED DROP FEED SEWING MACHINE

Table of Contents

1) SPECIFICATIONS	5
2) INSTALLATION	6
3) INSTALLING THE THREAD STAND	6
4) ATTACHING THE KNEE LIFTER PAD	8
5) ADJUSTING THE HEIGHT OF THE KNEE LIFTER	8
6) ATTACHING THE POWER CORD AND KNEE LIFTER CONNECTOR.....	9
7) INSTALLING AND ADJUSTING THE PEDAL	9
8) UNDERSTANDING THE PEDAL.....	10
9) LUBRICATION.....	11
10) STITCH LENGTH AND REVERSE.....	12
11) REPLACING NEEDLES	13
12) WINDING AND REPLACING THE BOBBIN	14
13) UPPER THREADING	15
14) LED LIGHT	16
15) UNDERSTANDING THE CONTROL PANEL.....	17
- SECTION A	17
- SECTION B	17
- SECTION C	17
- SECTION D	17
16) KEY DESCRIPTION	18
NAME	18
ICON	18
DESCRIPTION	18
NAME	19
ICON	19
DESCRIPTION	19
FEATURES OF THE TN-9000CQE	20

1) SPECIFICATIONS

Thank you for the purchase of your new Titan TN-9000C. This machine is a drop-feed machine used for general garment fabric and light-weight to medium-weight materials. The TN-9000C is often used in the manufacturing of garments to light upholstery.

	TN-9000C
Max sewing Speed	5,000 SPM
Max Stitch length	7 MM
Needle	DBx1 (287WH) #70/10~110/18
Presser foot lift	6 (by hand) 14 by knee or AK
Motor	550W Full servo motor
Oil	TITAN 032 (Virgin mineral oil ISO032)

Needle size depends on material, threads and speed of sewing. To better understand needle sizes please use the following chart as a guide.

Material	Examples	Needle size	Thread	Point Style
Light weight woven	Batiste, Organza, Linen, Light Cotton	80/12	Spun Poly T-27, T-35	R – Regular
Light weight stretch	Jersey, Lingerie, Tricot	80/12	Spun Poly T-27, T-35	BP – Ball point
Medium woven	Quilting, Wool, Satin	90/14	Spun Poly T-27, T-35	R – Regular
Medium Stretch	Fleece, Synthetic	90/14	Spun Poly T-27, T-35	
Heavy Woven	Denim, Tweed, Light Canvas	100/16	Nylon T-30, T-45	R – Regular
Light Leathers/Upholstery	Canvas, Cork, Suede, Up to 3oz	100/16	Nylon T-30, T-45	R – Regular, LL – Leather tip, D-Tip
Medium Leathers/Upholstery	Rabbit skin, Deer, up to 7oz	110/18	Nylon T-70	R – Regular, LL – Leather tip, D-Tip

2) INSTALLATION

The oil pan ④ should rest on the four corners of the machine table groove. Mount rubber hinge seat ⑤ on the table and fix it on the table with a nail.

Fix two rubber seats ① on side A (operator's side) using nails ② as illustrated above. Fix two cushion seats ③ on side B (hinged side) using nails, screws or a rubber-based adhesive.

Then place under cover ④ on the fixed seats.

Fit knee lifter pressing rod ⑥. Fit hinge ⑦ into the opening in the machine bed, and fit the machine head to table rubber hinge seat ⑤

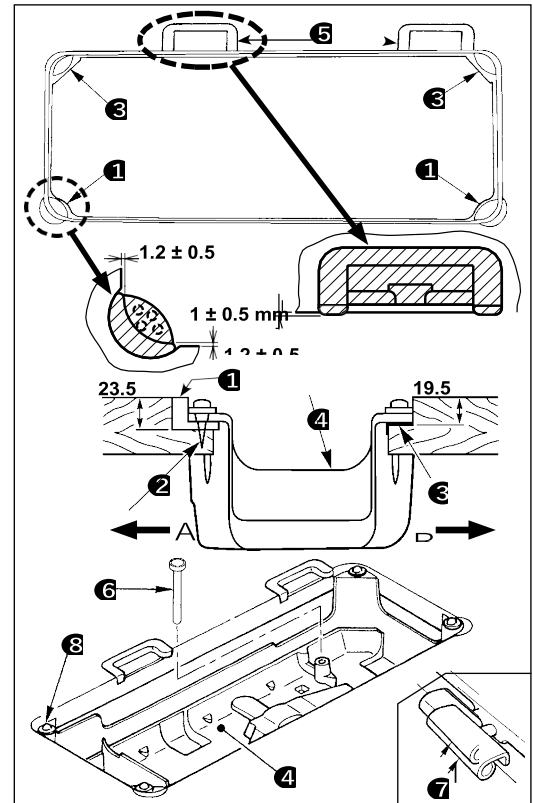

3) INSTALLING THE THREAD STAND

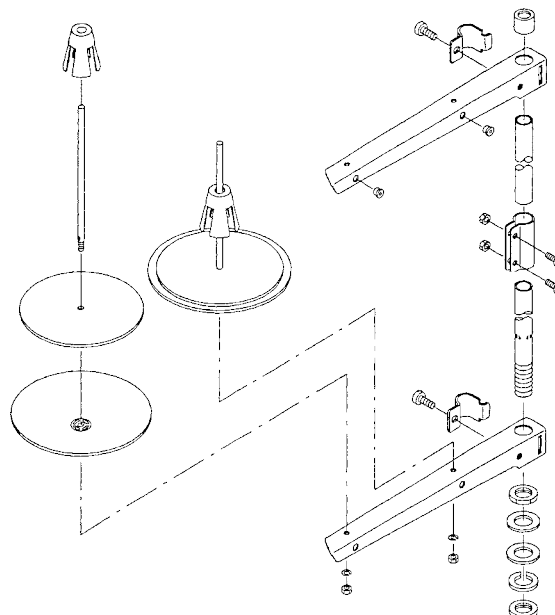

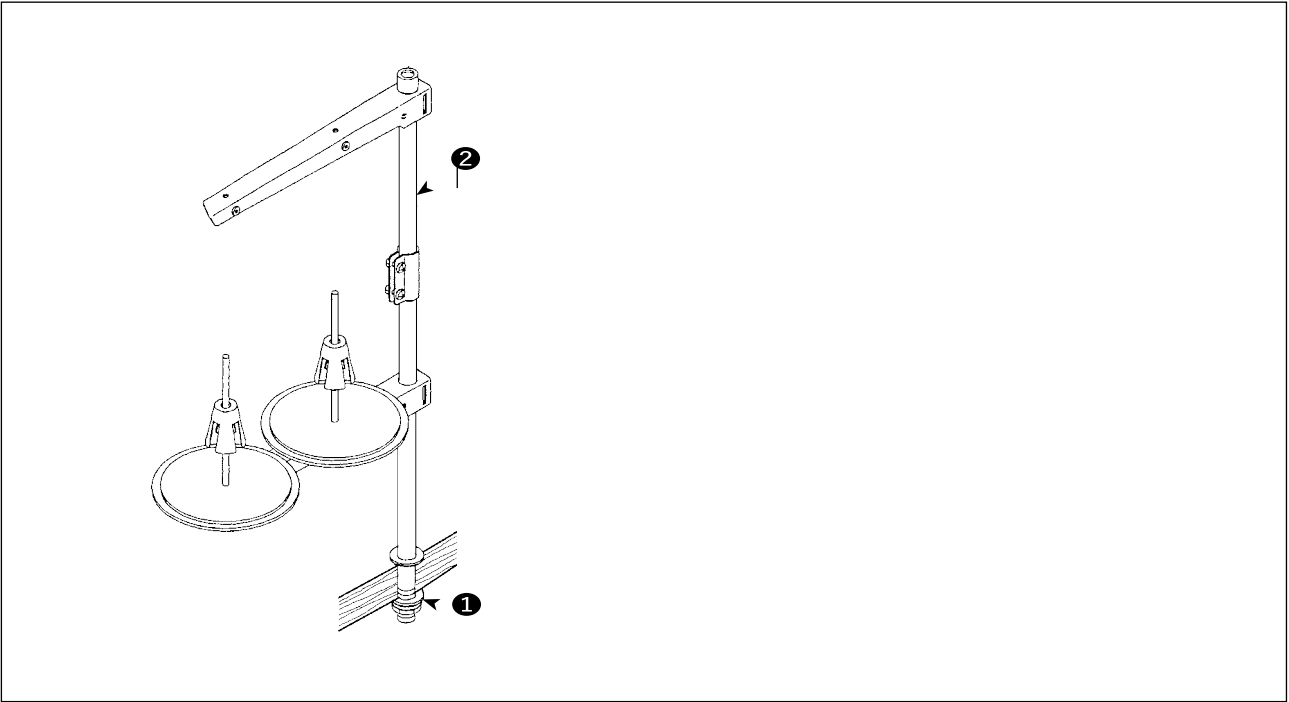

Assemble the thread stand unit as shown in the picture above and insert it in the hole in the machine table. Tighten nut ①.

4) ATTACHING THE KNEE LIFTER PAD

Insert knee lifter pad ① into knee lifter joint block ② and tighten it with bolt ③.

* Adjust the position of knee lifter pad ① to comfortable place for your knee.

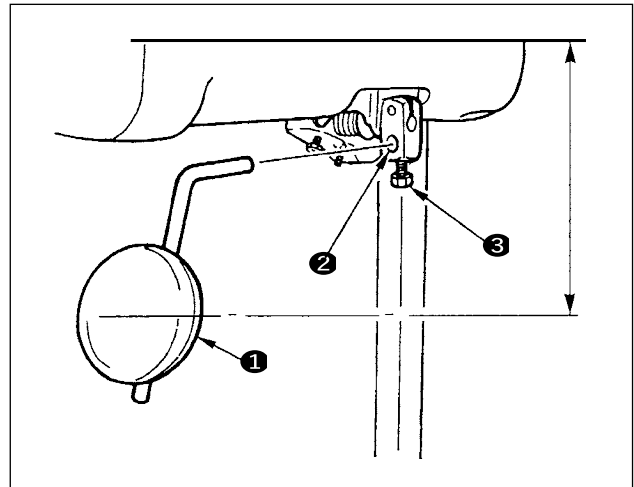

5) ADJUSTING THE HEIGHT OF THE KNEE LIFTER

The default height of the presser foot lifted using the knee lifter is 10 mm. While the AK (auto-knee lifter) can lift higher, it is possible for you to adjust the presser foot lift up to 15 mm using knee lifter by adjusting screw ①.

Before adjusting this, ensure the needle bar will clear the presser foot when the foot is in the highest position and the needle bar is in the lowest position.

If the adjustment screw ④ is incorrectly positioned, the presser foot will not lower down completely onto the material and cause the machine to “float” on top of the material.

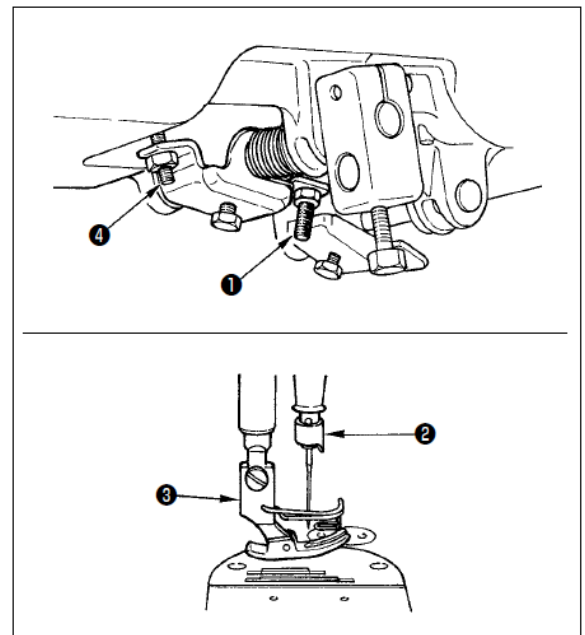

6) ATTACHING THE POWER CORD AND KNEE LIFTER CONNECTOR

Line 1 is the foot control connector and should be plugged into the connector on the board on the back side of the machine

Line 2 is the power connector and it should be plugged into the lower connector on the board on the back side of the machine

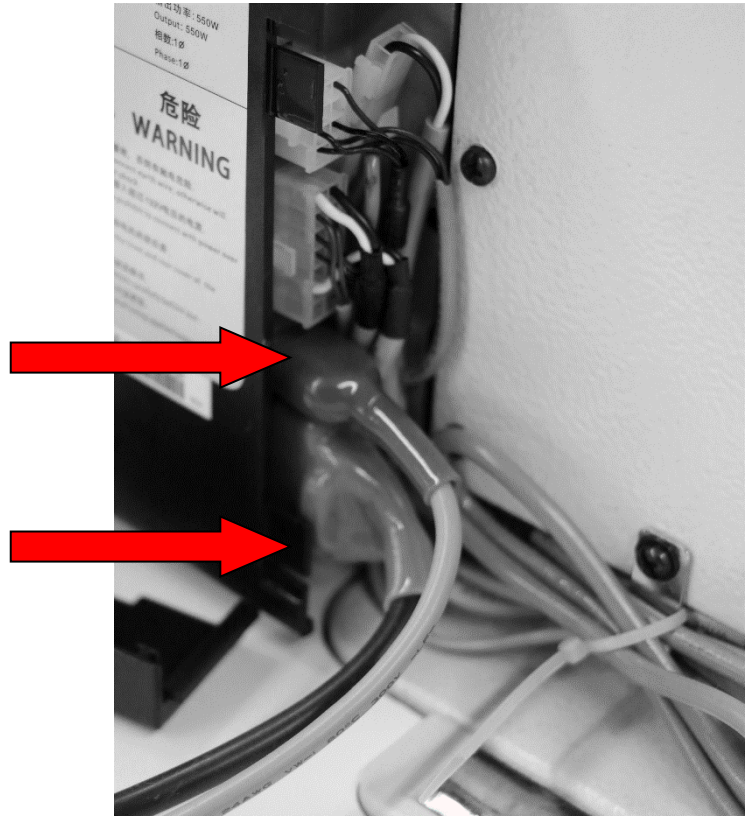

7) INSTALLING AND ADJUSTING THE PEDAL

Move pedal ③ to the right or left as illustrated by the arrows so that motor control lever ① and connecting rod ② are straightened.

The pedal tilt can be freely adjusted by changing the length of the connecting rod ②.

Loosen adjust screw ④, and adjust the length of connecting rod ②.

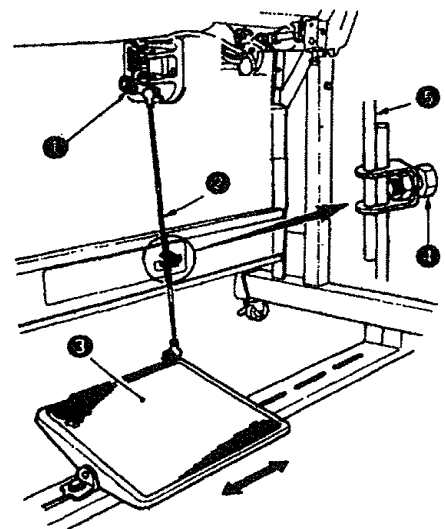

8) UNDERSTANDING THE PEDAL

The pedal has five distinct positions:

- When you press the foot lightly on your toe (ref A), the machine will run at a slow speed.
- The further you press the pedal on your toe (ref B), the machine will run faster until you press the pedal completely and reach the top speed.
- When the pedal is in the neutral position (ref C), the machine should not run. The machine stops (with its needle up or down) when you reset the pedal to its original position.
- The machine trims threads when you fully depress the back part of the pedal (ref E)

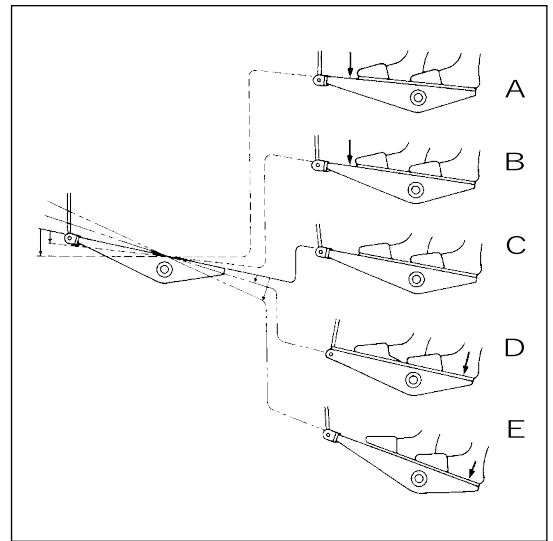

- When the auto-lifer (AK device) is used, one more operating switch is provided between the sewing machine stop switch and thread trimming switch.
- The presser foot goes up when you lightly depress the back part of the pedal (ref D), and if you further depress the back part, the thread trimmer is actuated.
- When starting sewing from the state that the presser foot has been lifted with the Auto-lifter and you depress the back part of the pedal, the presser foot only comes down.
- If you reset the pedal to its neutral position during the automatic reverse feed stitching at seam start, the machine stops after it completes the reverse feed stitching.
- The machine will perform normal thread trimming even if you depress the back part of the pedal immediately following high or low speed sewing.
- The machine will completely perform thread trimming even if you reset the pedal to its neutral position immediately after the machine started thread trimming action.

9) LUBRICATION

WARNING :

While the oils used in this machine are mineral oils, please take precautions to ensure the proper handling of these lubricants and chemicals that may be used throughout the machine and maintenance of the machine. To prevent the occurrence of an inflammation or rash, immediately wash the related portions if oil adheres to your eyes or other parts of your body. If oil is mistakenly swallowed, diarrhea or vomiting may occur.
KEEP OUT OF REACH OF CHILDREN

The TN-9000C uses a fully automatic oil bath system. This means the machine sits in a large bath of oil and has a gear pump system that pushes the oil throughout the machine. While this is one of the most maintenance friendly systems available, it is very important to routinely take the following steps to ensure your machine is kept in the best possible condition.

- Prepare to fill your oil tank on installation with the oil provided with your machine. To fill the oil, carefully tilt your machine back onto the headrest to expose the oil tank.
- Once the machine is laying back, clean the oil pan from any debris that may have been introduced during travel or installation.
- Inspect the oil drain plug (ref A). Ensure it is tight and not going to leak. While here, inspect that foam seal (ref B) that travels around the oil pan and keeps a seal to the machine. This will ensure no excess oil is splashed out of the oil pan.
- Make sure the knee lifter arm is in place. This will actuate the knee lifter through the oil pan (ref C)
- Inspect that the magnet (ref A) is in the oil pan. This magnet is important to the operation of the machine. It will collect any excess metal or metal filings (that may be a byproduct from the manufacturing process) that may drop into the oil pan and stop these from being pulled into the oil pump.
- Once you have taken all these steps, fill the oil pan with the oil. It should come to the upper "HIGH" line. The oil level should be above the "LOW" line and below the "HIGH" line.
- Lower the machine carefully and turn the hand wheel to ensure there is no negative interaction with the motion of the machine.

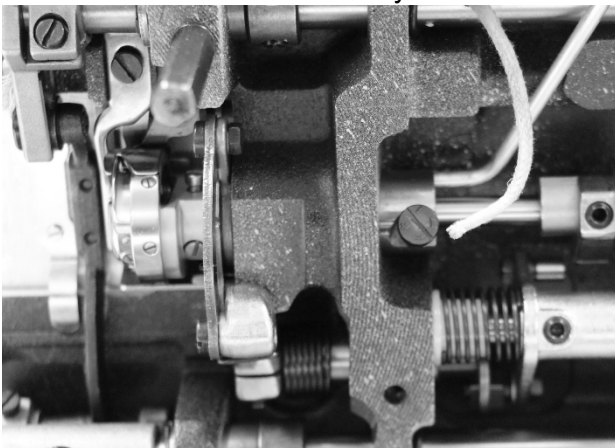
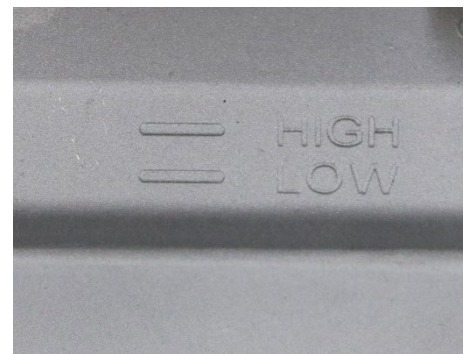
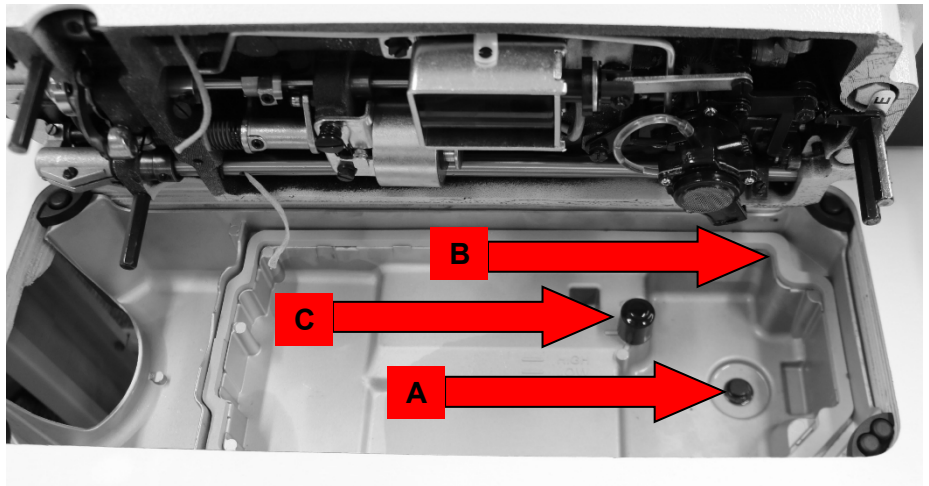

- If you tend to run the machine below 2000 spm as a habit, you may not be building enough pressure in the pump to lubricate completely. Periodically you should take some time to unthread the machine, remove the bobbin case, remove the needle, raise the pressure foot and run the machine for about 3 minutes to ensure the pump can allow the machine to be coated with oil throughout the internal areas.
- To increase the oil provided to the shuttle, you can turn the screw (ref D) clockwise to increase oil flow or counter-clockwise to decrease oil flow

10) STITCH LENGTH AND REVERSE



The TN-9000C is equipped with a locking stitch length dial. To adjust this, simply grasp the dial and press the black button on it to release the lock to turn.

Reverse is controlled by the lever AND can also be controlled by the switch beneath the tension unit.



11) REPLACING NEEDLES

Before handling the needle, foot, or threading, always make sure the power is off on the machine as to prevent injury if the machine abruptly runs.

The TN-9000C uses a DBx1. Use the proper needle in accordance with the thickness of thread used and the kinds of the materials. A helpful chart can be found on page 5.

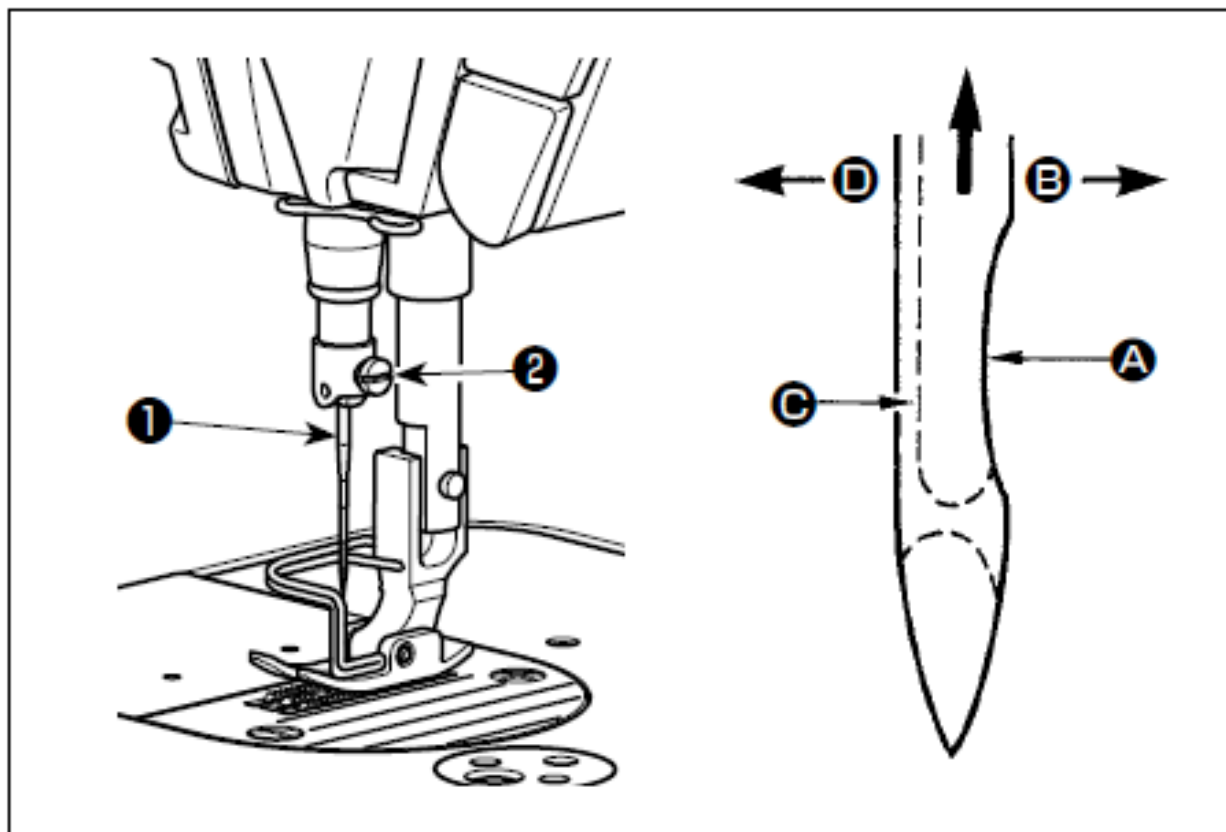

- Turn the hand wheel until the needle bar reaches the highest position.
- Loosen needle screw ②, and hold needle ① with its scarf (ref A) facing the inside of the machine (ref B)
- Insert the needle fully into the top of the needle bar. Ensure a positive connection with the top of the needle bar hole before tightening.
- Securely tighten screw ②.
- Check that long groove (ref C) of the needle is facing exactly to the outside of the machine (ref D)

12) WINDING AND REPLACING THE BOBBIN

- 1) Push the bobbin down onto the bobbin winder pin as far as it will go down (ref 1)
- 2) Thread the tension unit (ref 8) in thru the first thread guide with the thread between the tension discs and back out the other side guide. Then, wind clockwise the end of the bobbin thread on the bobbin several times.
- 3) Press the bobbin winding lever (ref 2) in the direction of (ref 3) and start the sewing machine. The bobbin rotates in the direction of (ref 9) and will stop when the bobbin winding lever senses that the bobbin is full. Remove the bobbin and cut the bobbin thread with the thread cut retainer (ref 7).
- 4) When adjusting the winding amount of the bobbin thread, loosen setscrew (ref 4) and move bobbin winding lever (ref 2) to the direction of 5 to fill less or 6 to fill more. Then tighten setscrew (ref 4).

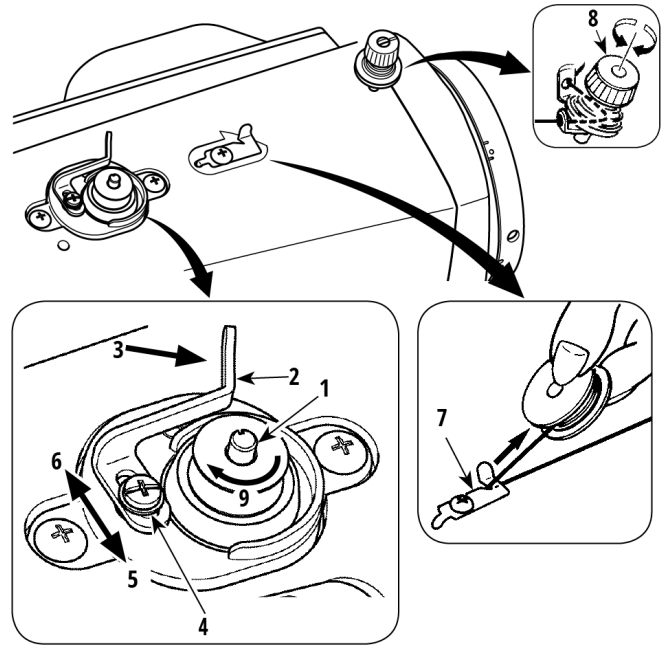

If the bobbin thread is winding unevenly, it may require an adjustment of the winder. To do this, simply loosen the nut (ref 1) on the bobbin winder tension unit to make your adjustment. Then take a small screwdriver and adjust the screw that the tension unit is based on (ref 2).

- If your bobbin is filling like (ref A) then you must raise the tension unit by **LOOSENING** (turning counter clockwise screw (ref 2)).
- If your bobbin is filling like (ref C) then you must lower the tension unit by **TIGHTENING** (turning clockwise) screw (ref 2).
- The perfect bobbin should look like (ref B)

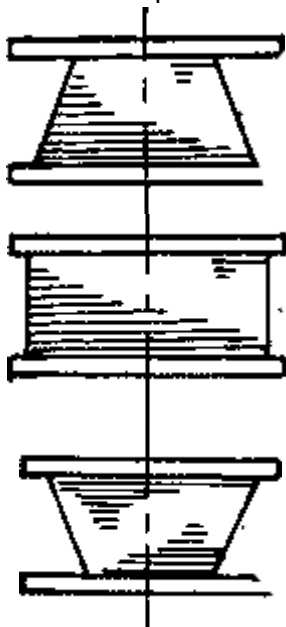

REF A

REF B

REF C



13) UPPER THREADING

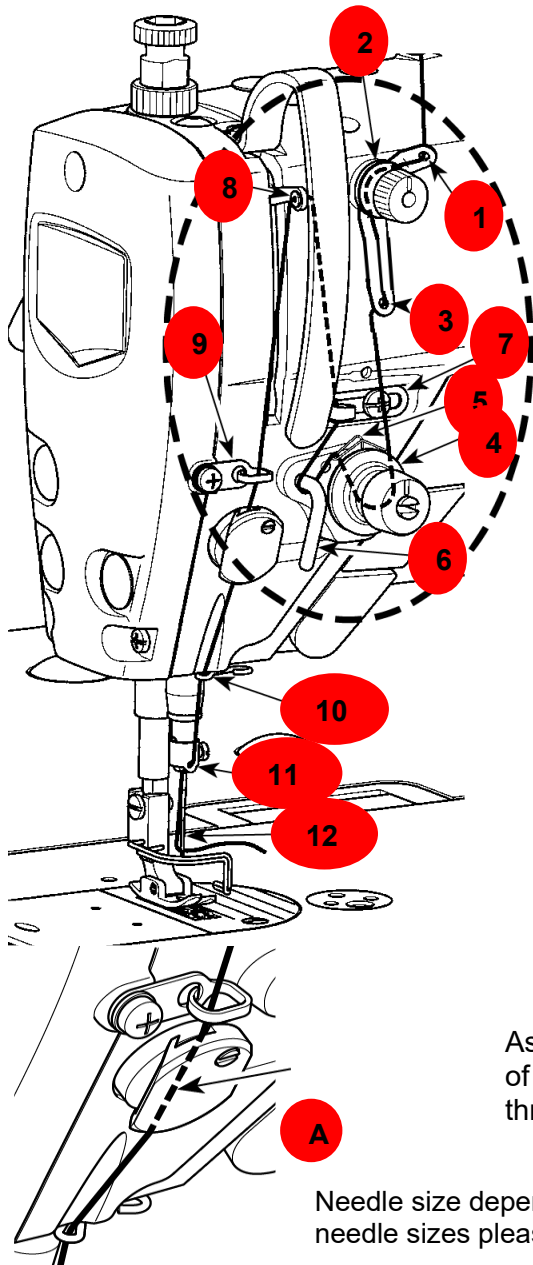

- When threading the TN-9000C, it is important to make sure the machine is turned off as to make sure the machine does not engage while your hands are near the moving parts
- Start by passing the thread thru the thread guide (ref 1)
- Ensure the thread goes between bother tension discs of the pretension (ref 2)
- Pass the thread thru the thread guide (ref 3)
- Wrap the thread thru the tension unit and ensuring the thread sits deep into the tension discs (ref 4)
- Wrap the thread around the check spring (ref 5) and back down under the thread stirrup (ref 6). At this time you should be able to pull the thread and see the check spring (ref 5) move up and down as you pull the thread.
- As you pull the thread up to the top, ensure the thread passes thru the guide (ref 7)
- Pass the thread from the right to the left thru the thread take up lever (ref 8)
- Pass the thread thru the guide (ref 9)
- As you pass the thread down the frame of the machine, please make sure you thread thru the magnetic clamp (ref A)
- Pass the thread thru the thread guide at the base of the frame (ref 10)
- Pass the thread thru the guide above the needle (ref 11)
- Thread the needle from the left to the right of the machine (ref 12)

As you pass the thread down the frame of the machine, please make sure you thread thru the magnetic clamp (ref A)

Needle size depends on material, threads and speed of sewing. To better understand needle sizes please use the following chart as a guide.

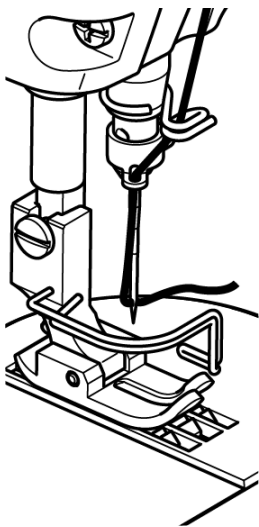

Material	Examples	Needle size	Thread	Point Style
Light weight woven	Batiste, Organza, Linen, Light Cotton	80/12	Spun Poly T-27, T-35	R – Regular
Light weight stretch	Jersey, Lingerie, Tricot	80/12	Spun Poly T-27, T-35	BP – Ball point
Medium woven	Quilting, Wool, Satin	90/14	Spun Poly T-27, T-35	R – Regular
Medium Stretch	Fleece, Synthetic	90/14	Spun Poly T-27, T-35	
Heavy Woven	Denim, Tweed, Light Canvas	100/16	Nylon T-30, T-45	R – Regular
Light Leathers/Upholstery	Canvas, Cork, Suede, Up to 3oz	100/16	Nylon T-30, T-45	R – Regular, LL – Leather tip, D-Tip
Medium Leathers/Upholstery	Rabbit skin, Deer, up to 7oz	110/18	Nylon T-70	R – Regular, LL – Leather tip, D-Tip

14) LED LIGHT

The TN-9000C is equipped with an LED light around the needle area. To turn on, off or change the intensity of the LED light, simply press the LED button. There are (3) settings to the intensity plus off.

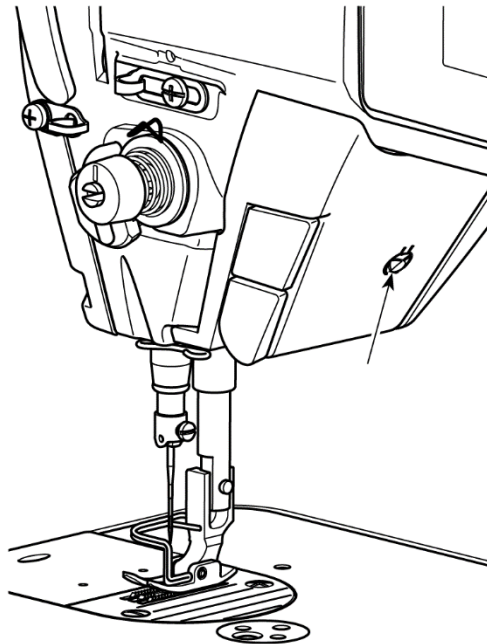

15) UNDERSTANDING THE CONTROL PANEL

The TN-9000C is equipped with a fully functional touch screen that helps to control almost every function of the machine. To help understand this, we will break the control panel into (4) parts.

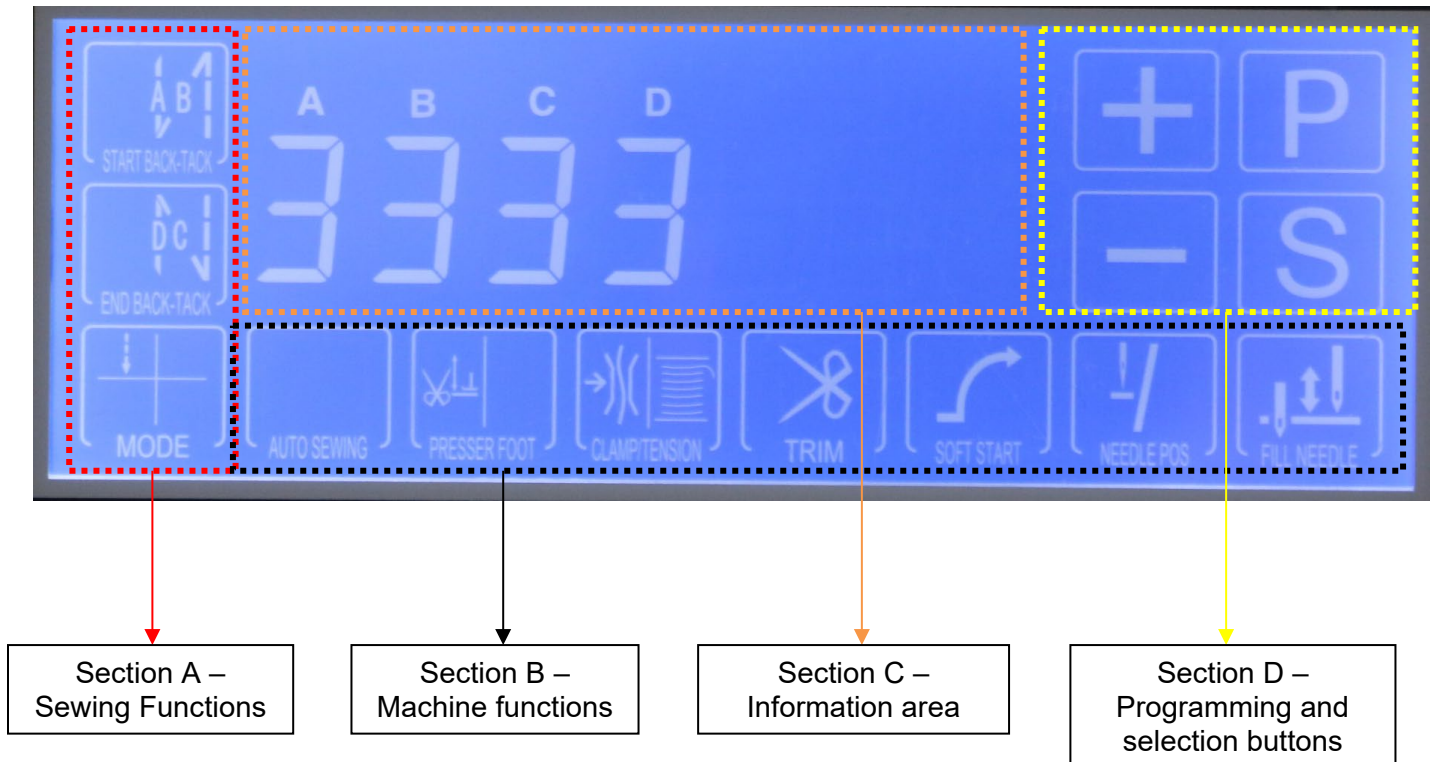

- SECTION A

Section A is all about how your machine will stitch and perform any special functions such as:

- Free sewing mode – This mode is all about freedom to sew normally. This is the most common and allows the user to operate with or without auto back tacking and sew for any length of time.
- Program sewing mode – This is particularly useful when you need to sew repetitively the same style over and over again. This helps when you want to have consistency in the sewing and speed. The machine will be programmed to sew exactly the same way and number of stitches over and over again.
- Bartack sewing mode – This mode is great if you wish to “tack” something in place. It will repeatedly sew back and forth at speed the predetermined amount of stitches over and over.
- Programmed chain sewing mode – This is a much less common feature but not less valuable. If you wish to continually and consistently do multiple functions over and over, this function allows you to CHAIN multiple programs together.

Section A also has information on the start back tack and end back tack programming

- SECTION B

Section B gives you quick information about the machine's optional controls like needle up/down stop, trim on/off and more









- SECTION C







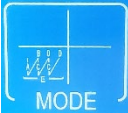

Section C is your information area where you will find out how many stitches are in the back tack, the speed of the machine and any information about what your program is.

- SECTION D

Section D is program button, save button, plus and minus

16)KEY DESCRIPTION

NAME	ICON	DESCRIPTION
Program enter key		Under normal mode, press the [P] key to enter the user parameter mode
Enter and save Key		Enter parameter values such items and their contents change after adjustment, need to press the [S] key to save the confirmation. Note: The parameters are saved by using the [S] key.
Set value increment / parameter increment key		A, B, C, D, E, F, G, H section, and increase the number of setting stitch. Increase the parameter in Parameter selection. Increase the setting value in Parameter value.
Set value decrease / parameter decrease key		A, B, C, D, E, F, G, H section, and decrease the number of setting stitch. Decrease the parameter in Parameter selection. Decrease the setting value in Parameter value.
Start backtack information		Execution starting back seam B segment or execution starting back seam (A, B segment) or double start tack (A, B segment) 2 times
End backtack information		Execution end back seam C segment or execution end back seam (C, D segment) or double end tack (A, B segment) 2 times
Bartack sewing mode		Once the treadle is toed down, all the seams of Bar-Tacking will be completed with D times, and then the thread will automatically be trimmed. Note: When the bartack Sewing starts, will not stop until the trimming cycle finished, except for the treadle heeled back to cancel the action.
Programmed chain sewing mode		When the display shows the icon, Programmed chain sewing mode is activated
Automatically sewing mode button		Does not work in Free sewing mode In Programmed chain sewing mode, one shot to the pedal, stitches number of E, F, G or H will be automatically performed. Toe down the pedal again and again to finish the rest sections until it finish

NAME	ICON	DESCRIPTION
Foot lift shortcut		Auto foot lift on/off When on:
		Foot lift is active when thread is cut
		Foot lift is active when motor stops
Thread clamp / Tension release button		This is to enable/disable thread clamp and tension release clamping.
Trim button		This is used to turn on/off the thread trim feature
Slow start function		The function for slow start sewing function
Quick needle up/down		Press this button to stop the move to the needle half stitch up/down
Needle stop Up/down	 	This button allows you to control where the needle position is when you take your foot off the pedal

FEATURES OF THE TN-9000CQE

The TN-9000C has a subclass of machine that is known as the TN-9000CQE or “Quilter’s Edition.” This utilizes the base model of the TN-9000C and all the features listed in this manual previous, but also includes some other add-on components and settings that allow the operator to expand on some great quilting features.

Included with the TN-9000CQE are the following components:

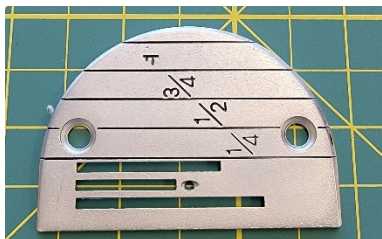

Needle Plate with Imperial Marking

This needle plate can be used to help with quilting measurements.

Needle Plate Shims

These shims are imperative when it comes to free-motion sewing (IE with the ruler foot). Normally you will receive between 5 and 10 shims to allow the needle plate to be raised enough to clear the feed dogs.



1/4” Presser Foot

This is used to sew 1/4" seams

Walking Foot

This walking foot is used when sewing quilted material to offer more even feeding. PLEASE NOTE TO LIMIT YOUR SPEED TO MAX 1500 SPM.



Free Motion Ruler Foot

This presser foot is used for free motion stippling and/or ruler work.

- 1) Users are required to read the operation manual completely and carefully before installation or operation.
- 2) The product should be assembled, tested and installed trained professionals.
- 3) Installation of a UPS (Uninterrupted Power Supply) is recommended for best protection. The use of an extension cable with multi-outlet for power connection is not recommended.
- 4) When connecting power supply cords to power sources, it is necessary to make sure that the power voltage checked and correct. Do not connect a 110V machine to a 220V service. This can cause severe damage.
- 5) Do not operate in direct sun light, outdoors area and where the room temperature is over 45°C or below 5°C.
- 6) Please avoid operating near the heater at dew area or at the humidity below 30% or above 95%.
- 7) Do not operate in area with heavy dust, corrosive substance or volatile gas.
- 8) The ground wire of power cord must be connected to the system ground of the production plant by proper size of conductions and terminals. This connection should be fixed permanent.
- 9) For safety, do not operate machine without all covers on to prevent harm from moving parts
- 10) When turning on the machine in the first time, operate the sewing machine at low speed and check the correct rotation direction.
- 11) Turn off the power before the following operation:
 - Connecting or disconnecting any connectors on the control box or motor.
 - Threading needle.
 - Raising the machine head.
 - Repairing or doing any mechanical adjustment.
- 12) Repairs and high level maintenance work should only be carried out by electronic technicians with appropriate training.
- 13) All the spare parts for repair must be provided or approved by Titan Sewing.
- 14) Don't use any objects or force to hit or ram the product.

Warranty

Warranty period of this product is 1 year dated from purchasing

Any trouble found within warranty period under normal operation, it will be repaired free of charge.

However, maintenance cost will be charged in the following cases even if within warranty period:

- 1) Inappropriate use, including: wrong connecting high voltage, wrong application, disassemble, repair, modification by untrained personnel, or operation without the precaution, or operation out of its specification range, or inserting other objects or liquids into the product.
- 2) Damage by fire, Earth quake, lightning, wind, flood, salt corrosive, moisture, abnormal power voltage and any other damage cause by the natural disaster or by the inappropriate environments.
- 3) Dropping after purchasing or damage in transportation by customer himself or by customer's shipping agency

Note: We make our best effort to test and manufacture the machine for the highest quality possible. However, it is possible that this product can be damaged due to external magnetic interference and electronic static or noise or unstable power source more than expected. Therefore it is recommended to ensure the machine and operation area is equipped with a stable ground and the power supply to the machine is the cleanest possible.

Titan Sewing Machines

www.titansewing.ca

Oct/2022
TN-9000C OWNERS MANUAL V2.00